

WINDWISER SW-4 switch panel

The function of the panel

The panel can connect 12V power from the boat's battery to its outputs and protect these devices with fuses. The on state is indicated by control LEDs.

Wiring and installing the panel

The inputs of the panel are IN+ and IN-. Connect the working battery of the boat here. Be careful not to swap the positive and negative battery inputs! The wire between the battery and the switch panel must have at least a cross-section that can withstand the total power of the load on the boat. It is recommended that the positive supply voltage is provided by a high-current main switch which can be used for this purpose.

Always connect the loads (top light, navigation lights, instruments, cabin lights, etc...) between the given output point and any "OUT" contact point. For example, connect the positive end of the top light to TOP+ and the negative end to any "OUT-" point. Strip the wires only enough so that the metal part of the wire does not protrude from the terminal. Tighten the screws on the terminal screws properly to avoid loose connections and contact failure. At the end of the wiring, it is advisable to clamp the wires together with cable ties for mechanical stability.

Wiring diagram of the panel, showing the battery and 2 consumers

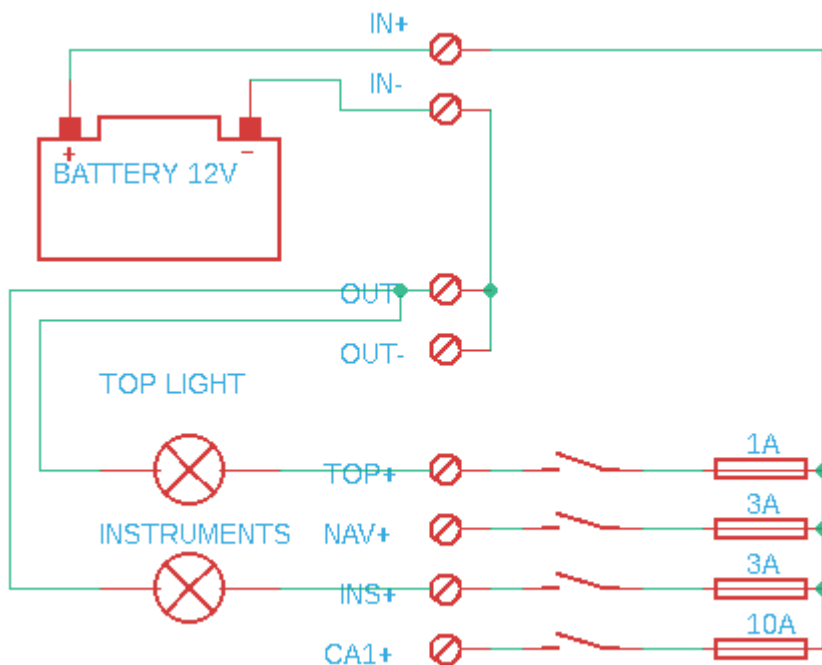

Abbreviations for panel connection points

TOP - Top light - 360° white top light on top of the mast

NAV - Navigation lights (red, green, white)

INS - Instruments - Electrical instruments of the vessel

CA1 - Cabin light

IN - Input

OUT - Output

Warning

The panel can only be used installed! The panel may only be installed inside the boat!

It is prohibited to connect the panel to 230/400V mains voltage!

Always connect the consumers with copper wires of appropriate thickness.

The fuses in the panel must not be replaced with a larger fuse than indicated!

Recommended wire cross-sections:

0,5mm ² 7A	0,75mm ² 10A	1mm ² 12A
1,5mm ² 16A	2,5mm ² 21A	4mm ² 27A
6mm ² 35A	10mm ² 48A	16mm ² 63A

Construction, dimensions and technical characteristics of the panel

Material: sintered A2 stainless steel

Fuse sizes: 5x20mm slow blow fuses

Dimensions: 160x80mm (width x height)

Installation dimensions: 140x60*55mm (width x height x depth)